

#10269, #09505, #10271



ORION

f/4 Newtonian



Instruction Manual

Never look at the sun with this telescope! Serious permanent eye damage, including blindness, can occur.

Introduction

Congratulations on your purchase of the Orion f/4 Newtonian telescope. Designed for serious astrophotography and rewarding visual observation alike, this fast, compact Newtonian reflector combines a premium parabolic optic, a precision 2" dual-speed Crayford focuser, and rugged mechanical construction into a powerful imaging platform.

With its short focal ratio, the telescope is exceptionally well suited for DSLR and dedicated astronomical imaging cameras, delivering wide-field views and sharp celestial detail. At the same time, when paired with optional eyepieces, it provides impressive visual performance for observing star clusters, nebulae, galaxies, and the Moon.

This manual will guide you through the assembly, setup, operation, and care of your telescope so you can get the best possible performance from it right from the start. Please read the manual completely before using the telescope or any included accessories. A few minutes of preparation will help ensure years of reliable operation and unforgettable nights under the stars.

What's Included

- Optical tube assembly
- Optical tube dust cap
- 8x50 crosshair finder scope
- Finder scope dovetail bracket
 - w/ rubber O-ring
- Pair of hinged tube rings
- Dovetail mounting bar
- Tube ring attachment screws (2)
- 2" to 1.25" eyepiece adapter
- 2" extension adapter



When unpacking the telescope, it is advisable to retain the packaging materials. In the rare event the instrument must be shipped back for service or return, the original packing will help ensure safe transport. Before proceeding with assembly, confirm all components listed in the parts inventory are present and in good working order.

Specifications

General

Optical design	Newtonian
Primary mirror figure	Parabolic
Focal ratio	f/4
Primary mirror coating	Aluminum with SiO ₂
Sec. mirror coating	Aluminum with SiO ₂
Finder scope	8x Optical

SKU #10269

Aperture	150 mm
Focal length	600 mm
Focuser	Linear Bearing 2"
Weight OTA	9.63 lb.

SKU #09505

Aperture	200 mm
Focal length	800 mm
Focuser	Linear Bearing 2"
Weight OTA	21.6 lb.

SKU #10271

Aperture	250 mm
Focal length	1,000 mm
Focuser	Linear Bearing 3"
Weight OTA	29.25 lb.

Setting Up the Telescope

Installing the Tube Rings

Your Orion f/4 Newtonian telescope includes a pair of hinged, felt-lined tube rings designed to securely support the optical tube assembly (OTA) while protecting the telescope's finish. Each tube ring features threaded mounting points for attachment to the included dovetail mounting bar.

Using the supplied socket head cap screws and included Allen wrench, attach both tube rings to the dovetail mounting bar.

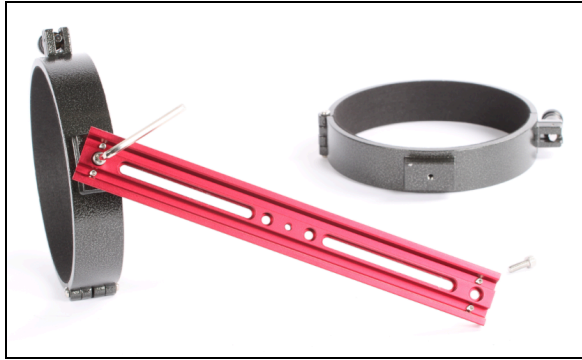

Once the rings are attached, open the hinged clamps and carefully place the optical tube into the rings. Position the front tube ring close to the focuser to achieve proper balance when the telescope is mounted. Close the rings and lightly tighten the clamp knobs.

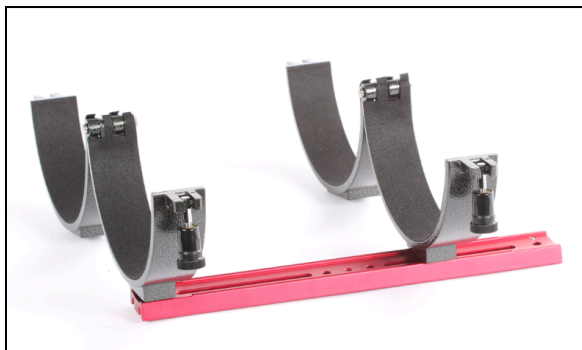

Before fully tightening the rings, rotate the optical tube to position the focuser in the most comfortable orientation for either visual observing or astrophotography. Once positioned correctly, tighten the tube ring clamps firmly enough to prevent movement without overtightening. At this point the tube ring to dovetail bar bolts can be fully tightened.

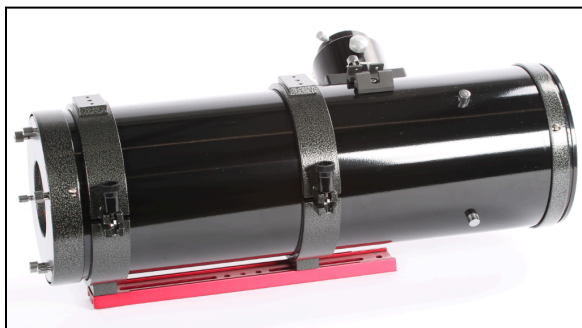

Crayford Focuser

The telescope is equipped with a precision all-metal dual-speed linear rail Crayford focuser featuring a 10:1 fine-focus reduction system and a linear bearing rail for enhanced stability and smooth operation. The 6' and 8" models utilize a 2" barrel focuser, and the 10" model utilizes a 3" drawtube; both accepting 2" accessories.

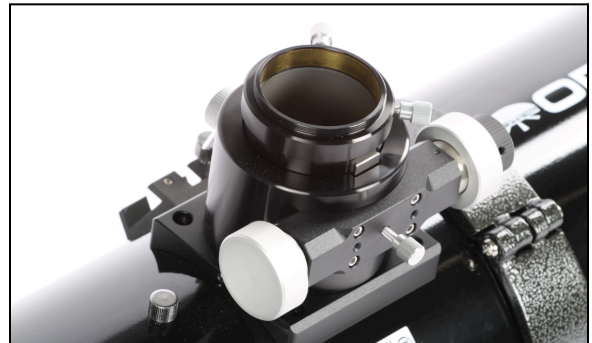

(6" and 8" focuser)



(10" focuser)

The focuser accepts standard 2" accessories directly through the drawtube collar and also includes a removable 1.25" eyepiece adapter for compatibility with 1.25" eyepieces and accessories.

If the focuser drawtube slips under the weight of your equipment, tighten the drawtube tension adjustment thumbscrew located on the underside of the focuser until smooth, secure

motion is restored. If the focuser feels too stiff, slightly loosen the tension adjustment.

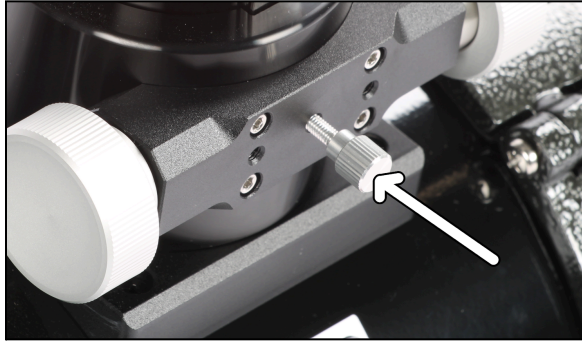

After achieving focus, the drawtube can be locked in place using the focus lock knob located on the top side of the focuser housing.

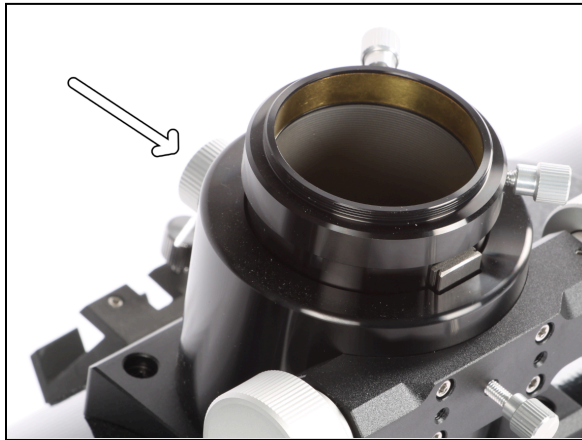

Fine Focus Adjustment

The dual-speed focuser includes both coarse and fine focusing controls for precise focusing accuracy.

The two large silver focus wheels provide rapid coarse focusing movement for bringing objects close to focus quickly. The smaller black focus wheel provides precision adjustment through a 10:1 reduction system. This means that ten rotations of the fine-focus knob equal one full rotation of the coarse-focus knob, allowing extremely precise control over focus position.

For best results, first use the coarse focus knobs to bring the target into approximate focus, then use the fine-focus control to achieve critical sharpness. This is especially

useful for high-magnification observing and astrophotography.

Installing the Finder Scope

The included 8x50 straight through crosshair finder scope allows you to easily locate and center celestial objects before viewing them through the main telescope.

Begin by removing the rubber O-ring from the finder bracket and sliding it onto the finder scope tube. Position the O-ring within, or just behind, the shallow groove located near the center of the finder scope body.



Next, loosen the two black nylon alignment screws on the finder bracket until their tips are flush with the inside surface of the bracket. While pulling back the chrome spring-loaded tension pin, slide the eyepiece end of the finder scope into the bracket from the end opposite the alignment screws.



Push the finder scope forward until the O-ring seats snugly inside the front opening of the bracket. Release the tension pin and lightly tighten the two nylon alignment screws to secure the finder scope.

To install the completed finder assembly onto the telescope, loosen the dovetail base thumbscrew on the main telescope and slide the finder bracket foot into the dovetail slot. Once fully seated, tighten the thumbscrew securely.



Focusing the Finder Scope

If the image seen through the finder scope appears blurry, the finder can be focused to match your eyesight.

Begin by loosening the knurled locking ring located behind the finder scope's objective lens cell. Rotate the lock ring several turns to free the objective assembly.

Next, aim the finder at a distant object and slowly rotate the objective lens cell clockwise or counterclockwise until the image appears sharp and well defined. Once proper focus is achieved, retighten the knurled locking ring to secure the adjustment.

Under normal use, the finder scope should not require additional focus adjustment once properly set.

Finder Scope Alignment

Proper alignment ensures an object centered on the red dot will also be centered in the telescope's eyepiece. Alignment is most easily performed during daylight. Follow the alignment procedure described in the next section to match the sight's aim with the optical axis of the telescope.

1. Remove the dust cover from the front of the telescope.

2. Install an eyepiece or camera in the focuser and point the telescope at a clearly defined land target (ideally at least a quarter mile away) such as the top of a telephone pole, tree, or building.
3. Center the target in the telescope.
4. Without moving the telescope, use the Finder's adjustment knobs to position the red dot directly on the target.
5. Once the finder's crosshair is centered on the target, verify the object remains centered in the main telescope. If necessary, re-center the target in the eyepiece and adjust the Red Dot Finder again. When the target is aligned in both the eyepiece and the Red Dot Finder, the finder is properly aligned with the telescope.

Collimation – Aligning the Optics

Collimation is the process of aligning the optics of the telescope so the mirrors are precisely positioned relative to each other and the telescope tube. For a reflector telescope, both the primary and secondary mirrors must be accurately aligned. The optics are aligned at the factory, and adjustments are often not required unless the telescope has been handled roughly.

Accurate alignment ensures the sharpest possible images and should be checked occasionally. With practice, collimation is straightforward and can be done in daylight. Keep in mind even a telescope without technically perfect collimation can still allow you to see good views of the night sky. While collimation is very important, don't let small deviations stop you from observing.

Perform collimation in a brightly lit room with the telescope pointed horizontally at a bright surface, such as a light-colored wall. Placing a piece of white paper opposite the focuser can help during alignment.

To check the current collimation, remove the eyepiece and look down the focuser. You should see the secondary mirror centered in the focuser, the reflection of the primary mirror centered in the secondary mirror, and the

reflection of the secondary mirror and your eye centered in the primary mirror reflection. Compare what you see with the provided illustration. If anything appears off-center, proceed with the collimation steps.

Precise collimation is easiest with a collimation tool like a Orion Collimating Eyepiece or Orion Laser Collimator. Though, rough collimation can be done by eye, if careful to keep your eye centered on the focuser.

Primary Mirror Center Mark

The telescope features a small ring in the center of the primary mirror. This center mark allows precise collimation. It does not affect optical performance because it exists in the shadow of the secondary mirror.

Aligning the Secondary Mirror

Begin with the secondary mirror. The secondary mirror adjustment screws are Allen screws. Look down the focuser at the secondary mirror. If the primary mirror reflection is not centered in the secondary mirror, adjust the tilt of the secondary mirror by loosening one screw and lightly tightening the others. The goal is to center the primary mirror reflection in the secondary mirror. Do not worry if the reflection of the secondary mirror itself is off-center at this stage. It will be corrected when adjusting the primary mirror. This process may take a few attempts to achieve precise alignment.



Aligning the Primary Mirror

Next, adjust the primary mirror. If the primary mirror reflection is centered in the secondary mirror but the secondary mirror reflection is

off-center, use the three spring-loaded collimation knobs and the three locking thumbscrews on the back of the optical tube. Loosen the locking thumbscrews slightly, then adjust each collimation knob in small increments, observing how the secondary mirror reflection moves. Repeat as needed until the reflection of the primary mirror's center mark is aligned with the collimating tool. Lightly retighten the locking thumbscrews to secure the mirror. A star test will confirm accurate collimation.

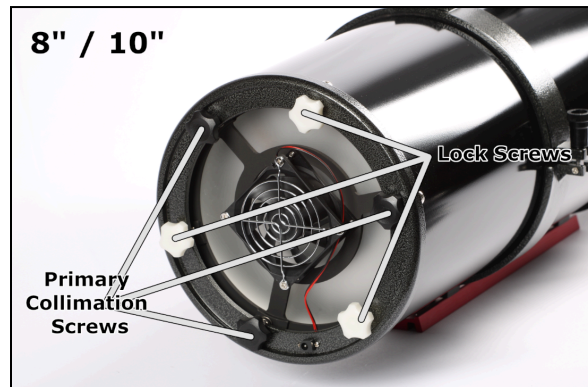
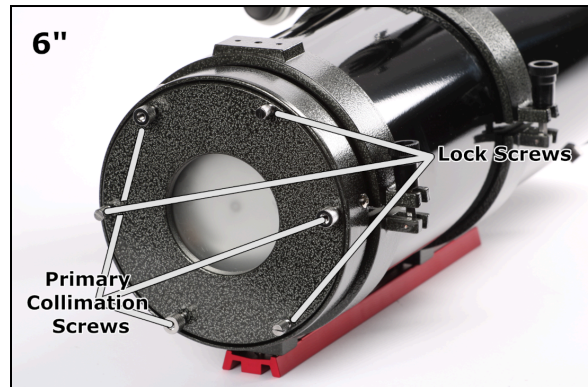

Star Testing the Telescope

At night, point the telescope at a bright star and center it in the eyepiece. Slowly defocus the star using the focuser. If collimation is correct, the out-of-focus star should appear as a symmetrical circle with the shadow of the secondary mirror centered, similar to a donut hole. If the shadow is off-center or the disk is unsymmetrical, further adjustment to the primary mirror is needed. Keep the star centered during testing; this is critical. Make slight adjustments to the telescope's position to center the star, if necessary. Polaris, the

North Star, is a convenient choice because it remains relatively fixed in the sky.

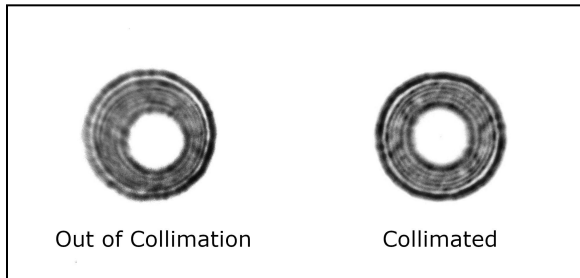

Operating the Telescope

The Orion f/4 Newtonian telescope was engineered first and foremost as a dedicated astrophotography instrument, but its high-quality optics also make it an excellent visual observing telescope.

Because fast Newtonian optical systems naturally produce coma, stars near the outer edge of the image field may appear stretched or distorted without optical correction. For the best possible astrophotography performance, the use of the optional Orion coma corrector is strongly recommended as a properly matched 2" coma corrector designed for f/4 Newtonians will dramatically improve edge-of-field sharpness and allow full use of your camera's imaging sensor without excessive cropping. Most coma correctors thread directly onto a DSLR T-ring or astronomical camera adapter and insert into the focuser like a standard 2" accessory.

Attaching a DSLR Camera

To connect a DSLR camera, you will need a compatible T-ring designed specifically for your camera model.

If using a coma corrector, attach the coma corrector to the DSLR T-ring assembly first, then insert the coma corrector into the telescope's 2" focuser collar. Tighten the focuser thumbscrews securely to hold the camera assembly in place.

Make sure that the T-ring thread size matches the thread size of your coma corrector.

If you are not using a coma corrector, a prime-focus camera adapter is required. Attach

the T-ring to the DSLR body, thread the prime-focus adapter into the T-ring, and insert the adapter barrel into the focuser's 2" accessory collar. Tighten the locking thumbscrews securely before use.

Attaching an Astronomy Camera

The telescope readily accepts astronomical CCD or CMOS imaging cameras equipped with either 1.25" or 2" nosepieces. A coma corrector may also be used in place of a standard nosepiece for improved image correction.

For cameras that utilize threaded T-connections instead of a nosepiece, a prime-focus adapter may be required. This adapter threads onto the camera and inserts into the focuser.

Depending on the camera design and sensor placement, the included 2" extension adapter may be necessary to achieve proper focus.

Most coma correctors also require precise spacing between the rear optical element and the imaging sensor. In these cases, T-thread spacer rings may need to be added between the camera and coma corrector. Consult the documentation provided with both your camera and coma corrector to determine the correct spacing requirements. The Orion coma corrector utilizes a 75mm back focus.

Visual Observing

Although optimized for astrophotography, the telescope also delivers excellent visual performance for observing the Moon, planets, star clusters, nebulae, and galaxies.

As with all Newtonian reflectors, the image orientation is rotated relative to normal terrestrial viewing, making the telescope unsuitable for daytime land-based observation.

For visual use, high-quality eyepieces are recommended to fully take advantage of the telescope's optical capabilities.

Most eyepieces will require the included 2" extension adapter in order to achieve focus. Insert the extension adapter into the focuser first, then install either a 2" eyepiece directly or a 1.25" eyepiece using the included 1.25" adapter.

If you are using a coma corrector designed for both visual and photographic use, the extension adapter may not be required.

Choosing an Observing Site

For the best viewing experience, choose a location as far as possible from artificial lights such as street lamps, porch lights, and car headlights. Bright lights interfere with dark-adapted night vision and reduce the number of visible stars and celestial objects. Avoid observing over rooftops or chimneys, which can produce warm air currents that distort the image. Observing from indoors, even through an open window, should also be avoided because temperature differences between indoor and outdoor air can blur and distort the view.

Whenever possible, travel away from city lights to darker rural skies. Under a dark sky, the number of visible stars and deep-sky objects increases dramatically.

Cooling the Telescope

All optical instruments require time to reach thermal equilibrium. The larger the telescope and the greater the temperature difference between indoor storage and outdoor conditions, the longer it takes to stabilize. Allow at least 20 minutes for the telescope to acclimate to the outdoor temperature before beginning high-magnification observations.

Allow Your Eyes to Dark-Adapt

Moving from a well-lit area into nighttime darkness will not immediately reveal faint nebulae, galaxies, star clusters, or even many stars when visually observing. Eyes take approximately 30 minutes to reach about 80% of their full dark-adapted sensitivity. As night vision develops, more stars will appear, and faint details in objects viewed through the telescope will become clearer.

To maintain night vision while working in the dark, use a red-filtered flashlight instead of white light. Red light preserves dark adaptation and allows you to see what you are doing without reducing sensitivity. Flashlights with

red LED lights are particularly effective. Keep in mind nearby porch lights, street lights, and car headlights can also compromise night vision.

Objects to Observe

Once the telescope is set up and aligned, the next step is deciding what to explore in the night sky.

The Moon

The Moon is one of the easiest and most rewarding targets for observation. Its craters, maria, and mountain ranges are visible even from a distance of 238,000 miles. Because the Moon goes through different phases, each night provides a slightly different view. The best time to observe is during a partial phase, when shadows along the terminator, the line between the illuminated and dark portions of the lunar surface, highlight surface details. A full Moon is very bright and lacks shadows, making it less ideal for detailed observation. Observing the Moon when it is high above the horizon provides the sharpest images.

The Planets

Planets move across the sky rather than remaining fixed like stars, so their positions change nightly. To locate them, consult a sky calendar, astronomy magazines, online astronomy charts, or smartphone apps. Venus, Jupiter, and Saturn are the brightest objects after the Moon, while other planets may appear star-like in a small telescope. Higher magnification is recommended for observing planets and even then, they will still appear very small through this telescope.

Jupiter is the largest planet and an excellent target. Through the telescope, the disk of Jupiter can be seen, along with its four largest moons: Io, Callisto, Europa, and Ganymede. The disc of the planet will likely be smaller than expected.

Saturn is famous for its rings. Depending on the tilt, the rings may appear edge-on or broadside. A steady atmosphere is important for a clear view. Titan, Saturn's brightest moon, is often visible nearby.

Venus is extremely bright and can sometimes be seen during daylight. At its peak brightness, Venus appears as a thin crescent rather than a

full disk, and no surface markings are visible due to dense cloud cover.

The Stars

Stars will appear as points of light through the telescope. While stars cannot be magnified into disks, their colors can be observed, and many double or multiple star systems can be resolved. The two-color, double star, Albireo in Cygnus, is a popular target. Slightly defocusing a star can sometimes enhance its color.

Deep-Sky Objects

Under dark skies, the telescope can reveal faint objects such as gaseous nebulae, open clusters, globular star clusters, and galaxies. Most deep-sky objects appear as dim gray shapes rather than the colorful images often

seen in photographs. Patience, dark-adapted eyes, and a location away from light pollution are essential. Without dark-adapted eyes, most deep sky objects are extremely challenging to view. As observing skills develop, more subtle details and structures become visible.

Star charts, planetarium programs, apps, and planispheres are helpful tools for locating deep-sky objects. Low-power scanning of the Milky Way with the 20 mm eyepiece is a rewarding way to explore the dense fields of stars. Maybe you'll stumble across one of the great nebulae! The Milky Way is especially impressive on summer and winter evenings.

Orion StarGuard 2 Year Warranty

Visit telescope.com for more information about the Orion StarGuard 2 Year Warranty.